

TRBoxter 600 kg - 22 m/min, low voltage control with frequency inverter

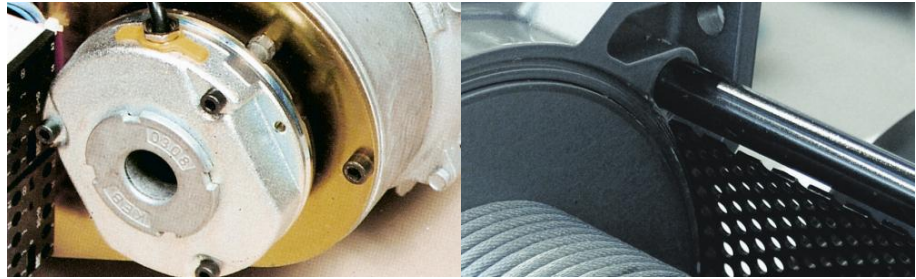

Compact electric winch 600 kg. Range of multifunctional electric winch offering many rope attachments, rope outlets and options.

Use:

- Lifting and hauling/pulling operations
- High operating factor
- Industry
- Building and public works
- Integration into many types of devices, cranes...
- Pulling carriages or wagons with a two-way system
- Installation and extraction of parts in ovens
- Hanging chandeliers
- Boat haulage
- Doors lifting, traps opening
- Material lifts
- Stage industry
- Swimming pool roofs...

Comply with Machines Directive 2006/42/EC and standard NF E N 14492-1.

Technical properties

- Welded steel drum protected by perforate plate, adjustable according to the outlet of the rope. Large flanges for a large rope capacity.
- Reliable and very safe cable clamp. Caged nut for winch multi-position fixing.
- Aluminium casing.
- Robust and compact, it benefits of a high operating factor.
- Asynchronous, three phase motor 230/400 V - 50 Hz. P = 3 kW.
- The low voltage control protects the user from electrical risks. It makes it possible to operate a wide range of options (limit switch, radio control, load limiter, rope slack switch...), and offers a variation of the winding speed with gradual starting and stopping.
- Reliable electronic and electric components.
- Very low voltage, 24 V remote control with socket, IP 65 protection.
- Limit switch obligatory when lifting.
- 190 V direct current electromagnetic brake.
- Electrical equipment under sealed cover.
- Reducer sealed in oil bath with helical gears.
- Fixation points identical to the TRB model allowing old TRB to be replaced.
- Lengthened drum models: standard length of drum and drum capacity x 1,5.
- Available options: rope press-roller, grooved drum, specific paint, chassis, drum length on request, rain cover, timer,

tarpauline cover...

Technical characteristics of TRBoxter 600 kg - 22 m/min, low voltage control with frequency inverter

References	TRBOXTER603VV20
Capacity 1st layer kg	750
Capacity top layer kg	600
Nb of layers	4
Wire rope cap. 1st layer m	19
Wire rope cap. top layer m	93
Wire rope Ø mm	7
Adjustable speed 1st layer m/min	1,8-18
Adjustable speed top layer m/min	2,2-22
FEM	1Am
Motor kW	3
Power	3Ph-230/400V
Weight (without wire rope) kg	104

Dimensions

References	TRBOXTER603VV20
A mm	574
B mm	304
C mm	107,5
D mm	Ø 159
E mm	318
F mm	Ø 12,5
L (with limit switch) mm	456
L (without limit switch) mm	516
G mm	246
H mm	391
I mm	62
J mm	29
K mm	495,5
M mm	152

N mm

T mm

152

290

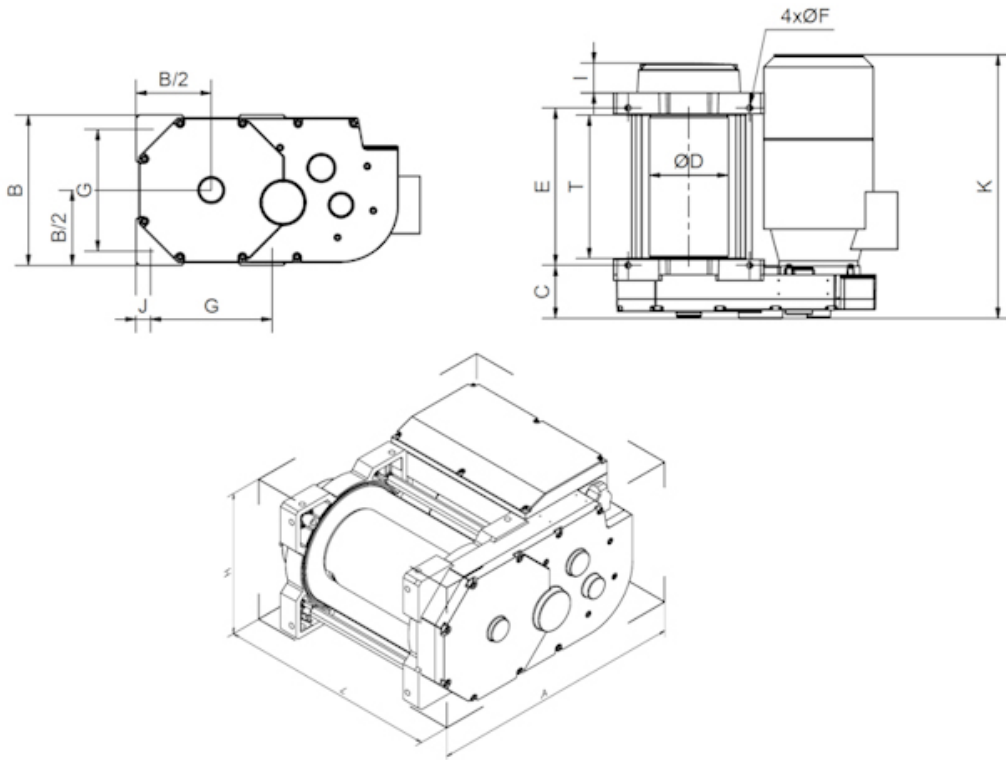

Technical characteristics of the other models of the range

References	TRBOXTER250VV9	TRBOXTER250VV14	TRBOXTER250VV21	TRBOXTER500VV4	TRBOXTER350VV9
Capacity 1st layer kg	290	290	290	600	400
Capacity top layer kg	250	250	250	500	350
Nb of layers	3	3	3	3	3
Wire rope cap. 1st layer m	16	16	16	12	16
Wire rope cap. top layer m	56	56	56	42	56
Wire rope Ø mm	5	5	5	7	5
Adjustable speed 1st layer m/min	0,8-8	1,3-13	2-20	0,4-4	0,8-8
Adjustable speed top layer m/min	0,9-9	1,4-14	2,1-21	0,5-5	0,9-9
FEM	1Am	1Am	1Am	1 Bm	1Bm
Motor kW	0,75	0,75	1,1	0,75	0,75
Power	1Ph-230 V or 3Ph-230/400 V	1Ph-230V or 3Ph-230/400V	1Ph-230V or 3Ph-230/400V	1Ph-230V or 3Ph-230/400V	1Ph-230V or 3Ph-230/400V
Weight (without wire rope) kg	50	49	54	50	50

References	TRBOXTER350VV14	TRBOXTER350VV26	TRBOXTER353VV42	TRBOXTER500VV11	TRBOXTER500VV21
Capacity 1st layer kg	400	400	400	600	600
Capacity top layer kg	350	350	350	500	500
Nb of layers	3	3	3	3	3
Wire rope cap. 1st layer m	16	16	16	12	12
Wire rope cap. top layer m	56	56	56	42	42
Wire rope Ø mm	5	5	16	7	7
Adjustable speed 1st layer m/min	1,3-13	2,6-26	3,9-39	1-10	2-20
Adjustable speed top layer m/min	1,4-14	3-30	4,2-42	1,1-11	2,2-22
FEM	1Bm	1Bm	1Bm	1Bm	1Bm
Motor kW	1,1	2,2	3	1,1	2,2
Power	1Ph-230V or 3Ph-230/400V	1Ph-230V or 3Ph-230/400V	3Ph-230/400V	1Ph-230V or 3Ph-230/400V	1Ph-230V or 3Ph-230/400 V
Weight (without wire rope) kg	54	62	66	54	62

References	TRBOXTER503VV32	TRBOXTER600VV10	TRBOXTER603VV15	TRBOXTER603VV20	TRBOXTER603VV30
Capacity 1st layer kg	600	750	750	750	750
Capacity top layer kg	500	600	600	600	600
Nb of layers	3	4	4	4	4
Wire rope cap. 1st layer m	12	19	19	19	19
Wire rope cap. top layer m	42	93	93	93	93
Wire rope Ø mm	7	7	7	7	7
Adjustable speed 1st layer m/min	2,6-26	0,9-9	1,5-15	1,8-18	2,6-26
Adjustable speed top layer m/min	3,2-32	1,1-11	1,9-19	2,2-22	3,2-32
FEM	1Bm	1Am	1Am	1Am	1Am
Motor kW	3	1,5	2,2	3	4
Power	3Ph-230/400V	1Ph-230V or 3Ph-230/400V	3Ph-230/400V	3Ph-230/400V	3Ph-230/400V
Weight (without wire rope) kg	66	101	100	104	107

References	TRBOXTER800VV5	TRBOXTER803VV10	TRBOXTER803VV13	TRBOXTER803VV17	TRBOXTER990VV5
Capacity 1st layer kg	950	950	950	950	1200
Capacity top layer kg	800	800	800	800	990
Nb of layers	3	3	3	3	3
Wire rope cap. 1st layer m	16,5	16,5	16,5	16,5	14,5
Wire rope cap. top layer m	59	59	59	59	53
Wire rope Ø mm	8	8	8	8	9
Adjustable speed 1st layer m/min	0,4-4	0,9-9	1,2-12	1,5-15	0,4-4
Adjustable speed top layer m/min	0,5-5	1-10	1,4-14	1,8-18	0,5-5
FEM	1Bm	1Bm	1Bm	1Bm	1Bm
Motor kW	1,1	2,2	3	3	1,1
Power	1Ph-230V or 3Ph-230/400V	3Ph-230/400V	3Ph-230/400V	3Ph-230/400V	1Ph-230V or 3Ph-230/400 V
Weight (without wire rope) kg	92	100	104	107	92

References	TRBOXTER993VV10	TRBOXTER993VV13	TRBOXTER993VV17	TRBOXTER1500VV4	TRBOXTER1503VV9
Capacity 1st layer kg	1100	990	990	1500	1500
Capacity top layer kg	990	990	990	1500	1500
Nb of layers	2	1	1	1	1
Wire rope cap. 1st layer m	14,5	14,5	14,5	11,5	11,5
Wire rope cap. top layer m	34	14,5	14,5	11,5	11,5
Wire rope Ø mm	9	9	9	11,5	11,5
Adjustable speed 1st layer m/min	0,9-9	1,2-12	1,5-15	0,4-4	0,9-9
Adjustable speed top layer m/min	1,1-11	1,2-12	1,5-15	0,4-4	0,9-9
FEM	1Bm	1Bm	1Cm	1Bm	1Cm
Motor kW	2,2	3	4	1,5	3
Power	3Ph-230/400V	3Ph-230/400V	3Ph-230/400V	1Ph-230V or 3Ph-230/400V	3Ph-230/400V
Weight (without wire rope) kg	100	104	107	101	104



HUCHEZ's advice

Fixation points identical to the TRB model allowing old TRB to be replaced, many rope attachments, rope outlets and options.



HUCHEZ
9, Grande Rue
60420 FERRIERES – France
☎ +33 (0) 3 44 51 11 33
Site internet : www.huchez.com
E-mail : contact@huchez.fr



**SERVICE
CLIENTS**

Pour en savoir plus, n'hésitez pas à nous contacter !
To know more, please contact us!