



HEAVY DUTY SCISSOR LIFT

- A range of maximum lift heights from 1050mm to 2900mm
- Manual or battery electric operation
- Robust construction
- Manoeuvrable
- Unique lift up lid to allow safe and easy maintenance - can only be lifted when table is in the closed position
- Quality British manufacture and design



TECHNICAL FEATURES

ALL MODELS

- Single double or triple lifts available
- Heavy duty arm, bearings and hydraulics
- Nylon bushes fitted at all arm end hinge points
- Heavy duty castor wheels one of which is fitted with a total stop brake as standard- prevents table from moving when loading and unloading
- All models fitted with an overload valve and slow lowering valve to control lowering speed
- The base frame is designed to give low closed height and maximum stability
- Each table is issued with operating instructions and a test certificate in conformance with EU Standards EN 1570 and BS:5323:1980

BATTERY ELECTRIC MODELS

- Models include 12v traction battery and charger
- Safety cut-off bar fitted to the underside of the platform stops table from lowering in the case of an obstruction
- Remote push button control up/down operation
- Emergency stop switch
- Safe design plug-in charger
- Strong electrical flex
- Electrical contacts/motors conform to EQ1570/ EN 60529



TECHNICAL SPECIFICATION

SINGLE SCISSOR TABLES

Capacity	C Raised Height	B Closed Height	Operation	E x A Platform W x L	E x D O/A W x L	F Handle Height	Wheel Dia	Approx Weight	Reference	Approx Lifting Time
800kg	1050	360	Manual	840 x 1350	870 x 1630	1040	150/200	222	SC-800-S-M	80 pumps
800kg	1050	360	Battery Electric	840 x 1350	870 x 1630	1040	150/200	270	SC-800-S-E	30 seconds
1250kg	1050	360	Manual	840 x 1350	870 x 1630	1040	150/200	230	SC-1250-S-M	80 pumps
1250kg	1050	360	Battery Electric	840 x 1350	870 x 1630	1040	150/200	278	SC-1250-S-E	25 seconds
1000kg	1050	360	Manual	1000 x 2000	1000 x 2350	1040	150/200	350	SC-1000-S-M	80 pumps
1000kg	1050	360	Battery Electric	1000 x 2000	1000 x 2350	1040	150/200	397	SC-1000-S-E	25 seconds

DOUBLE SCISSOR TABLES

Capacity	C Raised Height	B Closed Height	Operation	E x A Platform W x L	E x D O/A W x L	F Handle Height	Wheel Dia	Approx Weight	Reference	Approx Lifting Time
500kg	1900	490	Manual	840 x 1350	870 x 1630	1040	150/200	306	SC-500-D-M	80 pumps
500kg	1900	490	Battery Electric	840 x 1350	870 x 1630	1040	150/200	352	SC-500-D-E	30 seconds
800kg	1900	490	Manual	840 x 1350	870 x 1630	1040	150/200	315	SC-800-D-M	160 pumps
800kg	1900	490	Battery Electric	840 x 1350	870 x 1630	1040	150/200	363	SC-800-D-E	54 seconds

TRIPLE SCISSOR TABLES

Capacity	C Raised Height	B Closed Height	Operation	E x A Platform W x L	E x D O/A W x L	F Handle Height	Wheel Dia	Approx Weight	Reference	Approx Lifting Time
500kg	2900	655	Manual	840 x 1350	870 x 1630	1040	150/200	375	SC-500-T-M	468 pumps
500kg	2900	655	Battery Electric	840 x 1350	870 x 1630	1040	150/200	420	SC-500-T-E	105 seconds

Options

- Second brake wheel
- Stainless steel top cover
- Steel, zinc plated roller conveyor top (Increases closed / raised height by 60mm)
- Ball Top
- Bellows safety skirt

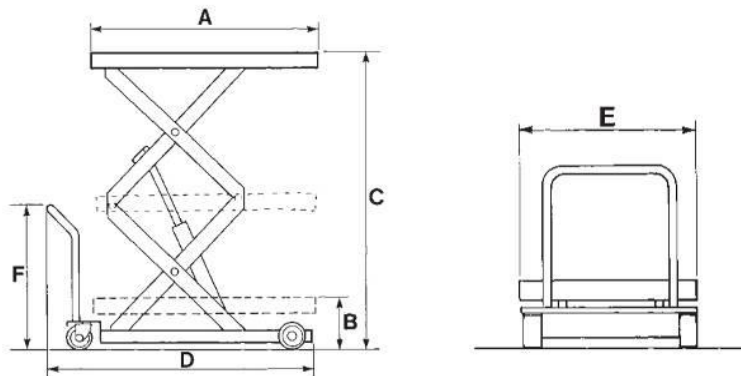

All dimensions are in mm unless otherwise shown